

SPECIFICATIONS

Standard Finishes:

Blown Glass: Alabaster White or Smoked Gray

Metal: Blackened Steel, Satin Nickel,
Satin Brass, Satin Copper or Satin Bronze

Specifications:

Dimensions: 13" D x 16.5" H + Stem

33 cm D x 41 cm H + Stem

Weight: 30 lbs / 13.6 kg

Light Source: 12V 6 Watt LED (included)

LED Drivers: CCT9W500 - 110V
UVC1225TD - 220V

Total Wattage (nominal): 3.1 w

Lumens (total): 680 lm

Stems & Canopies:

Standard Stem Lengths: 6", 12", 18" or 24"

15 cm, 31 cm, 46 cm or 61 cm

Additional Stem Lengths: 30", 36", 42" or 48"

76 cm, 91 cm, 107 cm or 122 cm
(up-charge applies)

Standard Canopy: 5" x 0.5" / 12 cm x 1.3 cm

Deep Canopy: Dimensions on request.

Custom finishes available upon inquiry.

Made and assembled in Canada. Item is UL & CE listed.

STANDARD FINISHES

Blown Glass:



Alabaster White

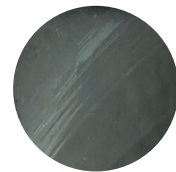

Smoked Gray

Metal:

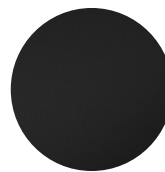

Blackened Steel

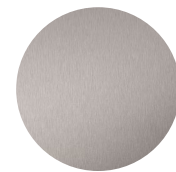

Satin Nickel



Satin Brass



Satin Copper



Satin Bronze

LED DRIVER

CCT9W500 - 110V

twentieth

sales@twentieth.net
323.904.1200
www.twentieth.net

Magnitude's CCT Series dimmable Constant Current LED driver is class 2 rated and designed to operate with MLV, ELV and CL dimmer switches (forward phase/ reverse phase / TRIAC). The driver's low profile case allows OEM's to easily incorporate it into Luminaires. A 5-year warranty is a standard on all of Magnitude's products.

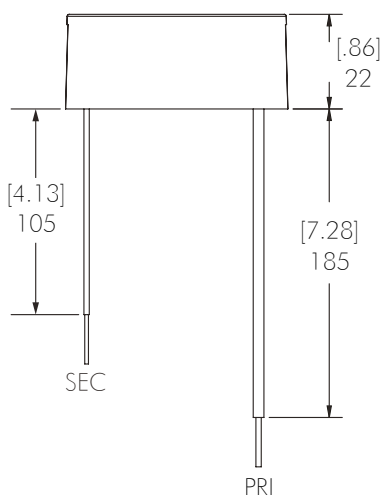
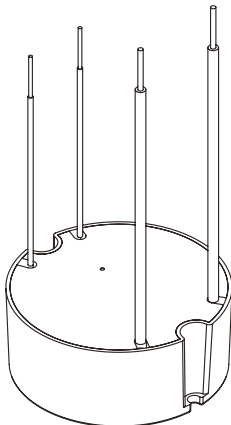
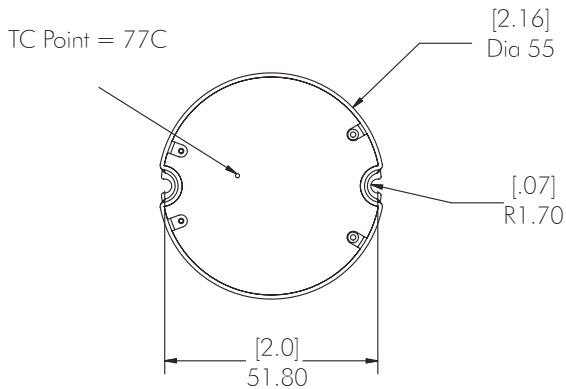

Features:

- Dimmable with MLV, ELV and CL dimmer switches (forward phase / reverse phase / TRIAC)
- Dim down to 5%
- Super compact case
- Class 2
- UL 8750
- Complies with FCC Part 15B
- Auto-Reset protection for short circuits, over-voltage and over-temperature

Specifications:

Input voltage	100 - 120VAC
Max output voltage	9W
Output voltage range	12 - 18.5 VDC
Output current range	500mA Nominal - 525 Max
Rated output power	6 - 9.25W
Efficiency at max load	> 82 %
THD at max load	< 20 %
Power factor at max load	> 0.9
Environment protection rating	IP21 - Dry and damp location
Tc case max	77c
Ambient op. temp.	-20c ~ 60c
Operating humidity	10% - 60%
Lifetime	50KHrs
Over voltage protection	Auto recovery
Open circuit protection	Max output voltage
Short circuit protection	Auto recovery
Surge protection	1KV
Weight	82g
Dimensions (inches)	2.16" D x 0.86" H
Dimensions (cm)	5.5 cm D x 2.2 cm H
Placement	Designed to fit in standard 4" junction box

LED DRIVER

UVC1225TD - 220V

twentieth

sales@twentieth.net
323.904.1200
www.twentieth.net

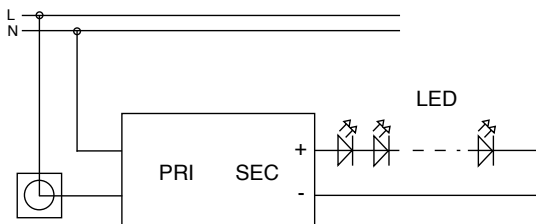
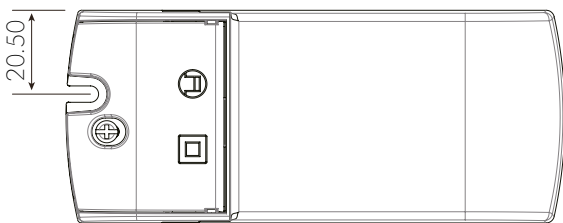
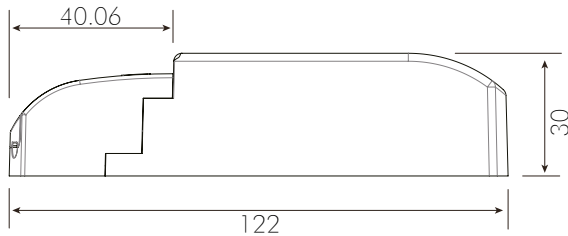

Features:

- Constant voltage output
- Fully isolated
- Short circuit, over current and over voltage protection up to 80% efficient
- Fire resistant plastic cover
- Compatible with leading and trailing edge dimmers
- 10 ~ 100% Dimming Load
- 10 ~ 100% Dimming range
- Mains dimmable
- Push terminals for easy installation
- IP44 design for indoor use
- 2 years warranty

Specifications:

Voltage	220V ~ 240VAC
Frequency	50-60 Hz
Current	0.2A
Inrush Current	<2.5A
Power Factor	0.95
Load Voltage	12V
No Load Voltage	12V
Current	2.08Av
Power	25W
Power Factor	> 0.95
Efficiency	80%
Over Load	Auto Recovery
Short Circuit	Auto Recovery
Over Voltage	Auto Recovery
Operating Temperature	-20 ~ +50°C
Storage Temperature	-40 ~ +70°C
Relative Humidity	5 - 95%
Safety Standard	Design refers to EN60598, EN61547, ENV55024, EN61000-4-2, 3, 4, 6, 8,11, EN61000-3-2, EN61000-3-3
EMI Standard	Meets Emissions to EN55022, EN55015 Class B
Lifetime	50K hrs at TC max (70c)
Weight	110g
Dimensions (inches)	4.8" x 2" x 1.2"
Dimensions (cm)	12.2 cm x 5.2 cm x 3 cm